

NOTES

- 1.) EXPANSION TANK SIZING PER CALCULATIONS. IF MORE THAN ONE EXPANSION TANK IS USED, CONNECT TO THE SAME POINT IN THE SYSTEM.
 - 2.) AIR SEPARATION AND PARTICULATE SCREEN REQUIRED. MAY BE A COMBO UNIT. LOCATION AS DETAILED IN HIGH POINT OF SYSTEM.
 - 3.) SUPPLY & RETURN MANIFOLD PER FIELD INSTALLATION. MIXING VALVES REQUIRED FOR RADIANT ZONES. CHECK VALVES MAY BE INTERNAL TO THE CIRCULATOR PUMPS.
 - 4.) THERMAL STORAGE TANK SENSORS MUST BE LOCATED IN DEEP WELL BENEATH INSULATION WITH SENSOR IN TANK WATER.
 - 5.) TANK TO TANK CONNECTION MUST BE MIN 1.5" PIPE OR FLEX CONNECTION WITH DUAL UNIONS. IF ISOLATION VALVES ARE USED, DO NOT REDUCE PIPE DIAMETER THROUGH VALVE.
 - 6.) MAINTAIN THERMAL STORAGE TANK TAPPING SIZE TO BOTH VALVES. REDUCE PIPE SIZE AT VALVE ONLY. KEEP TEE AS CLOSE TO TANK AS POSSIBLE
 - 7.) CENTER WELL ON TANKS NOT USED FOR PELLET BOILER CONTROL. PELLET BOILER CONTROL FROM TOP AND BOTTOM TANK SENSORS (SEE ELECTRICAL SCHEMATICS AND SUPPORT DOCS).
- ALL PIPING, CONNECTIONS AND SIZING PER LOCAL CODE. INSTALLATION OF EQUIPMENT MUST FOLLOW MANUFACTURER REQUIREMENTS. SEE SEPARATE INFORMATION REGARDING VENTING, ELECTRICAL & CONTROL.

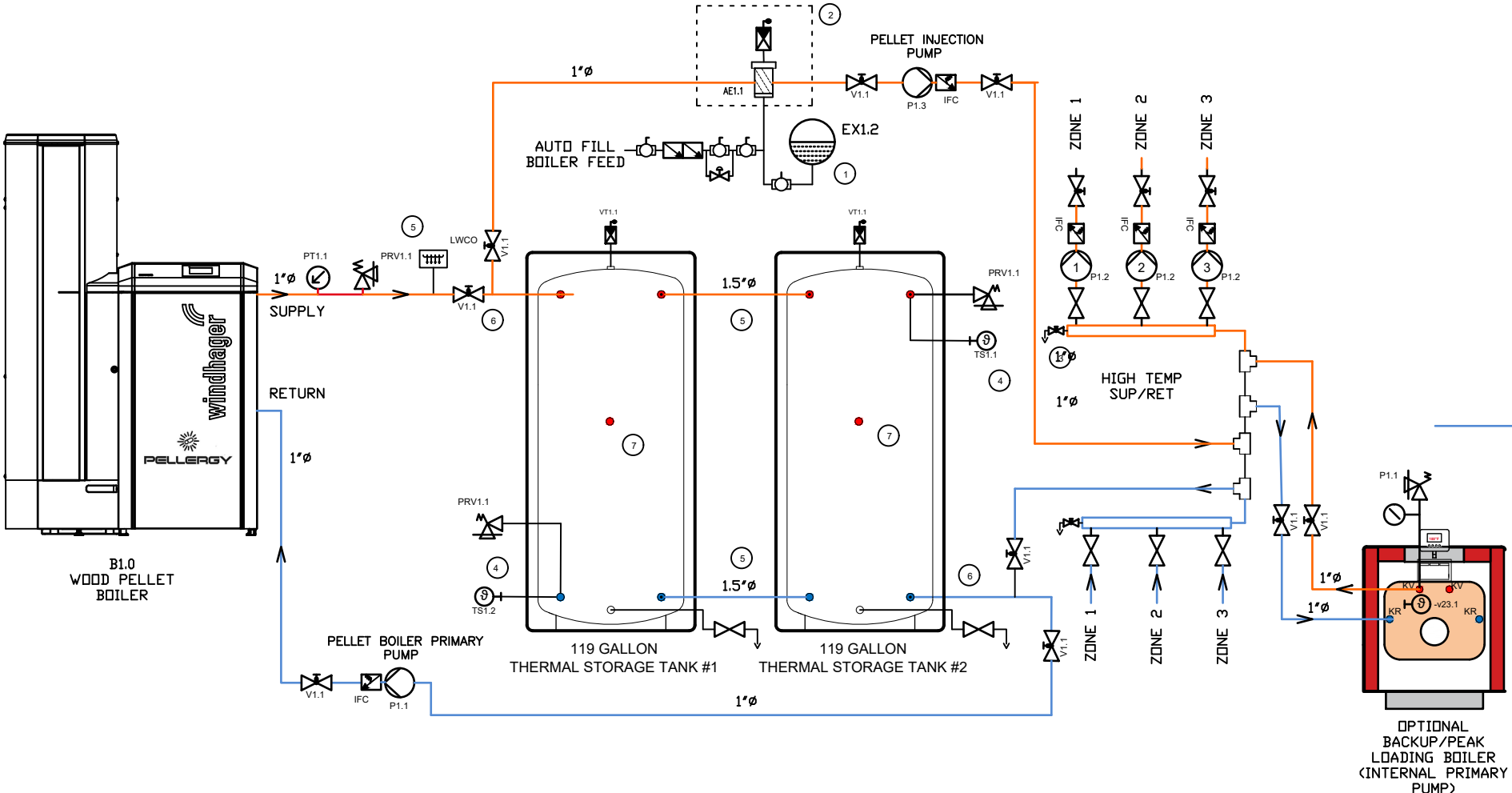

PELLERGY LLC	Order/offer:	Date: 2021 EXAMPLE	Installer: PELLERGY CERTIFIED INSTALLER	Pellergy/Windhager BioWIN 262 & 332	SCALE: NTS
WWW.PELLERGY.COM	Planner/engineer A.BOUTIN		Customer: NEW CUSTOMER	BOILER AND THERMAL STORAGE PIPING DETAIL	
Drawing: System Nr. example				REV NEW	PG1
					OF H1 Pages